

Principal characteristics

- The transducer's compactness makes it suitable for installation in small spaces and for detecting small shifts.
- The joint with up-take of slack and M4 threading provides greater tolerances in movement.
- Installation is simplified by the lack of electrical signal variation at output outside theoretical electrical stroke.
- Ideal for small mechanical devices, valves, and test tools and benches.

TECHNICAL DATA

Useful electrical stroke (C.E.U.)	25/50/75/100/125/150
Resolution	Infinite
Independent linearity (within C.E.U.)	see table
Displacement speed	≤ 5 m/s
Displacement force	≤ 1.2 N
Life	>25x10 ⁶ strokes, or 100x10 ⁶ operations, whichever is less (within C.E.U.)
Vibrations	5...2000Hz, Amax = 0,75 mm amax. = 20 g
Shock	50 g, 11ms.
Tolerance on resistance	± 20%
Recommended cursor current	< 0,1 mA
Maximum cursor current	10mA
Maximum applicable voltage	see table
Electrical isolation	>100MΩ a 500V~, 1bar, 2s
Dielectric strength	< 100 mA a 500V~, 50Hz, 2s, 1bar
Dissipation at 40°C (0W at 120°C)	see table
Actual Temperature Coefficient of the output voltage	< 1,5ppm/°C
Working temperature	-30...+100°C
Storage temperature	-50...+120°C
Case material	Anodised aluminium Nylon 66 G 25
Control rod material	Stainless steel AISI 303
Fixing	Brackets with variable longitudinal axise

MECHANICAL DIMENSIONS

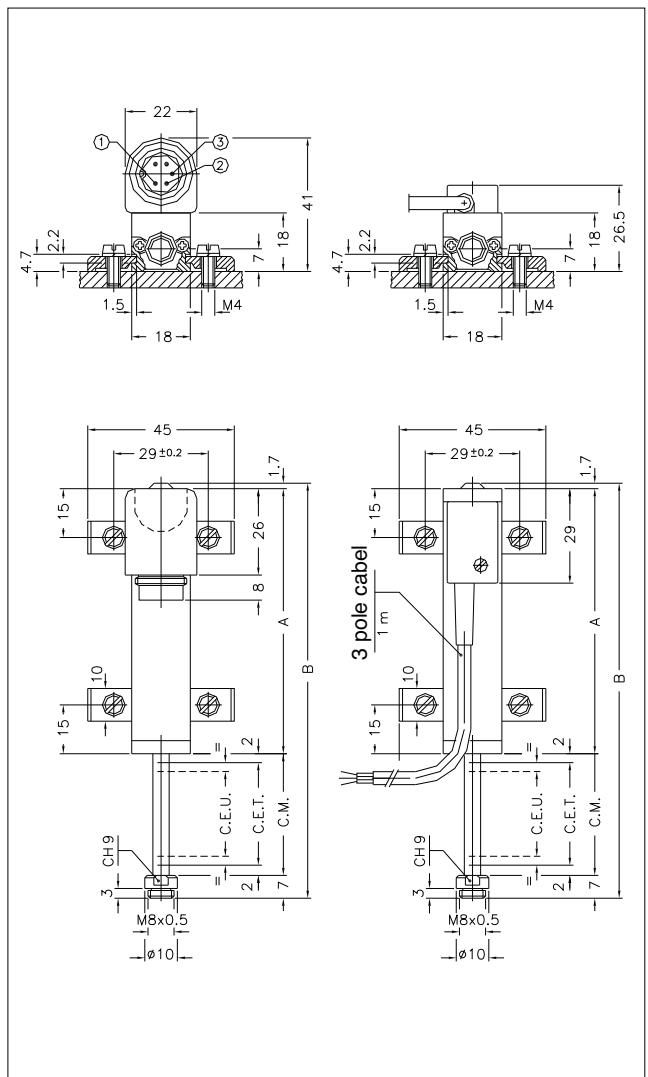

Important: all the data reported in the catalogue linearity, lifetime, temperature coefficient are valid for a sensor utilization as a ratiometric device with a max current across the cursor $I_c \leq 0.1 \mu A$.

MECHANICAL / ELECTRICAL DATA

Model		25	50	75	100	125	150
Useful electrical stroke (C.E.U.) +1 / -0	mm	25	50	75	100	125	150
Theoretical electrical stroke (C.E.T.) ± 1	mm	C.E.U. +1					
Resistance (on C.E.T.)	kΩ	1	5	5	5	5	5
Independent linearity (within C.E.U.)	± %	0.2	0.1	0.1	0.1	0.05	0.05
Dissipation at 40°C (0W at 120°C)	W	0.6	1.2	1.8	2.5	3	3.6
Maximum applicable voltage	V	25	60				
Mechanical stroke (C.M.)	mm	C.E.U. +5					
Case length (A)	mm	C.E.U. +49.5					
Total length (B)	mm	113.2	163.2	213.2	263.2	313.2	363.2

ELECTRICAL CONNECTIONS

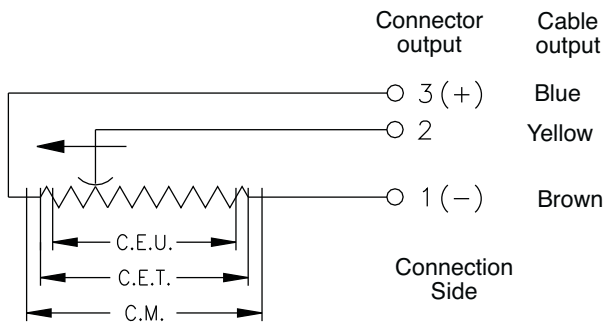

INSTALLATION INSTRUCTIONS

- Respect the indicated electrical connections (DO NOT use the transducer as a variable resistance)
- When calibrating the transducer, be careful to set the stroke so that the output does not drop below 1% or rise beyond 99% of the supply voltage.

COUPLING JOINT

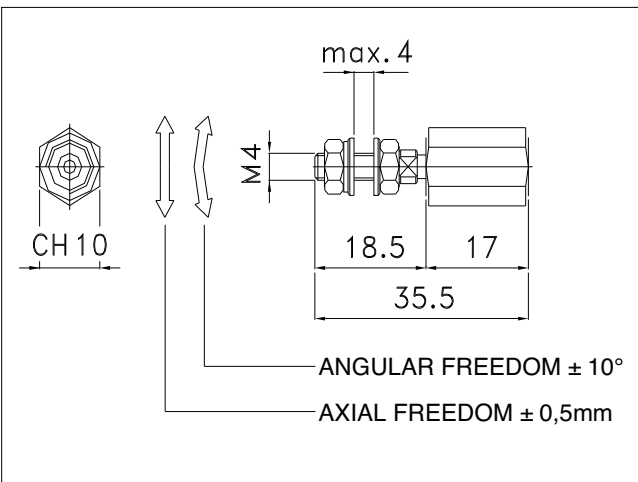

OPTIONAL FIXING KIT PKIT006

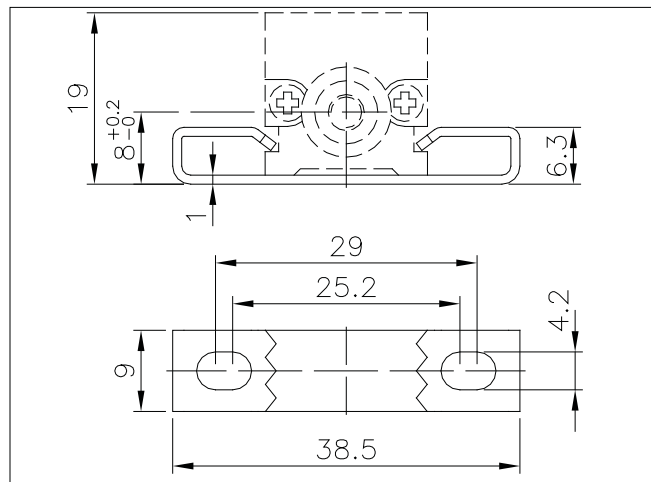

ORDER CODE

Displacement transducer **PA1**

3 pole PVC cable output 3x0.25 1m.	F
5 pole connector output DIN 43322	C

Model

S **M**

Cable length
(in meters)

This part of the code only applies to the model with cable output

No certificate attached	0
Linearity curve to be attached	L

Standard mounting brackets (PKIT005)	X
Optional mounting brackets (PKIT006)	S

Color of plastic heads (green)	0
--------------------------------	----------

0 0 0 X 0 0 0 0 0 0

Ex.: **PA1 - C - 100**

Displacement transducer model PA1, 5 pole connector output, useful electrical stroke (C.E.U.) 100mm

ACCESSORIES

STANDARD ACCESSORIES

Fixing kit: 4 brackets, M4x10 screws, grower	PKIT005
Fixing kit: 2 "wraparound" brackets (0000X000S00 configurator option)	PKIT006
Coupling joint	PKIT020

OPTIONAL ACCESSORIES

5-pin axial female PCB connector DIN43322 IP40 clamp for wire $\varnothing 4 - \varnothing 6$ mm	CON011
5-pin axial female PCB connector DIN43322 IP65 clamp PG7 for wire $\varnothing 4 - \varnothing 6$ mm	CON012
5-pin 90° radial female PCB connector DIN43322 IP40 clamp for wire $\varnothing 4 - \varnothing 6$ mm	CON013

GEFRAN spa reserves the right to make any kind of design or functional modification at any moment without prior notice